

Technical Specification

GOCO Nozzle [Strapless] (2", 2.5", 3" and 4" Pipe)

Description

Goyen's range of nozzles measurably increase developed pressures in filters during reverse pulse cleaning by balancing the flow through all holes along the blowtube, ensuring that the pulse jet is directed fully into the filters, and minimising the pressure drop through the blowtube holes. Goyen's nozzles ensure effective cleaning is achieved at An/Ap (total blowtube hole area/blowtube cross-sectional area) values up to 1.5, extracting maximum pulse performance from the diaphragm valves. Typical systems not using the Goco nozzle perform at 0.5 to 0.8.

Installation

For best performance, $H = (\text{Ø Filter} - 48) / 0.353$ (mm) or $H = (\text{Ø Filter} - 1.88) / 0.353$ (inches). Prepare $\text{Ø}34.1\text{-}34.5\text{mm}$ ($\text{Ø}1.34\text{-}1.36$ ") holes in the blowtube.

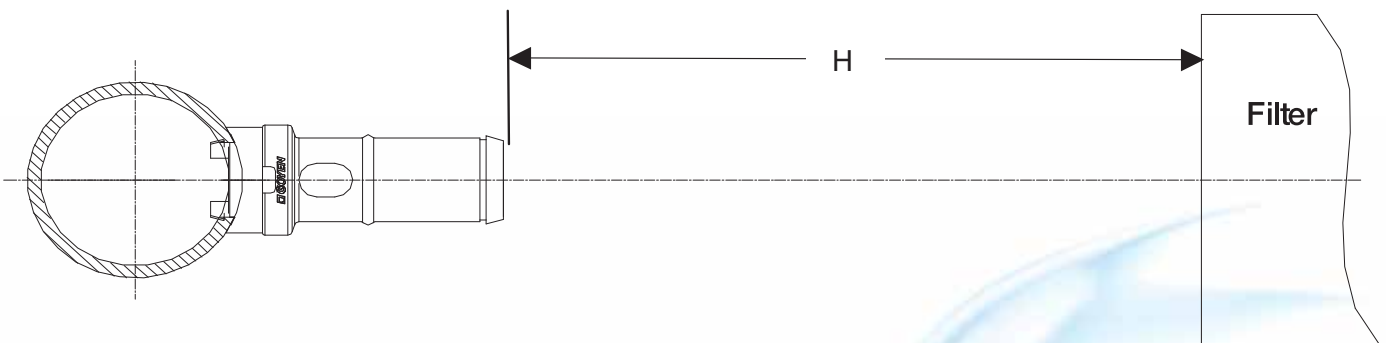
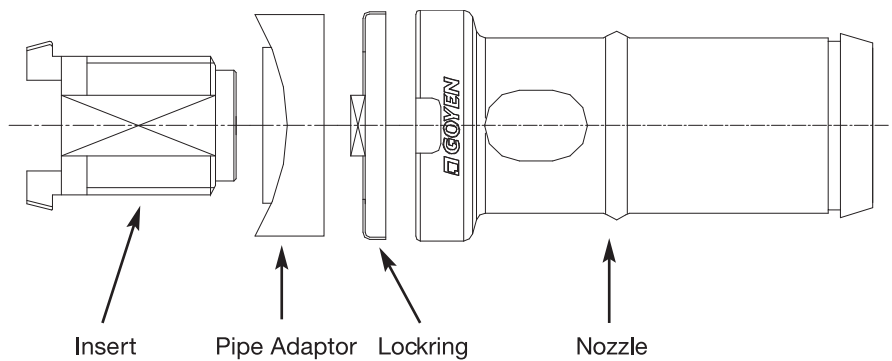

Suitable for

2", 2.5", 3" and 4" schedule 40 pipe diameters as used in reverse pulse jet filter cleaning applications and its variations including bag filters, cartridge filters, ceramic filters, and sintered metal fibre filters.

*** Please Note: Not intended for use in Gas Turbine applications**

1. Ensure holes prepared in the blowtube are free from burrs.
2. Assemble the insert into nozzle passing through the pipe adaptor and locking as illustrated above. Only screw the insert part way into the nozzle.
3. Align the insert lugs along the axis of the blowtube, and hook one lug into the blowtube
4. Swing the second lug up into the blowtube and slide the pipe adaptor up and onto the blowtube hole.
5. Screw the nozzle up onto the insert checking that all components are aligned. Hand tight is sufficient.
6. Dent the locking into one or both of the nozzle cavities, this will ensure the assembly is permanently locked in place. To remove the nozzle bend the dent out using a screwdriver blade.



(For detailed installation instructions, refer to DEINC-018 VNA).

Dimensions

(Dimensions in mm and [inches])

Item	Mass Kg (lbs)	Item	Mass Kg (lbs)
VNA50I-50	0.115 (0.254)	VNA50I-100	0.205 (0.452)
VNA62I-50	0.115 (0.254)	VNA62I-100	0.205 (0.452)
VNA76I-50	0.115 (0.254)	VNA76I-100	0.205 (0.452)
VNA102I-50	0.115 (0.254)	VNA102I-100	0.205 (0.452)

Order Code	Y mm (inches)	Order Code	Y mm (inches)
VNA50I-50	88 (3.46)	VNA50I-100	138 (5.43)
VNA62I-50	94 (3.71)	VNA62I-100	145 (5.68)
VNA76I-50	102 (4.03)	VNA76I-100	152 (6.00)
VNA102I-50	115 (4.53)	VNA102I-100	165 (6.50)

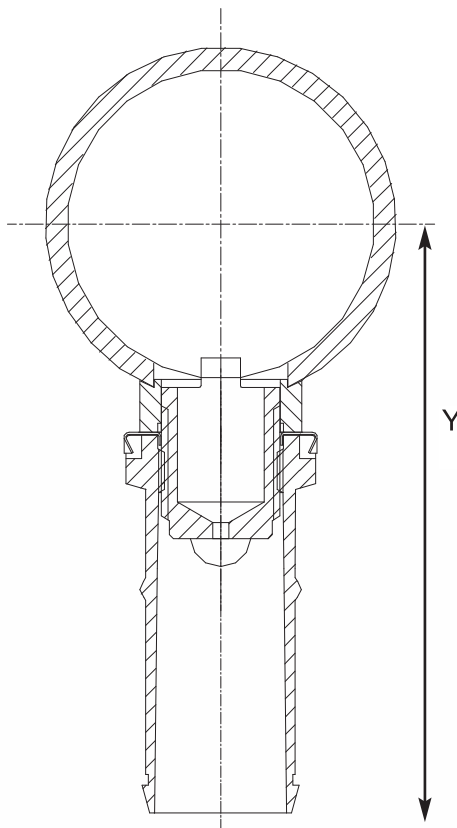

Order Code and Characteristics

Diecast Nozzles

Code	Schedule 40 Pipe (inches)	Description	Material	Temperature Range °C °(F)
VNA50I-50	2	Short barrel	Diecast aluminium & galvanised steel (locking)	-60 (-76) - 400 (752)
VNA62I-50	2.5	Short barrel	Diecast aluminium & galvanised steel (locking)	-60 (-76) - 400 (752)
VNA76I-50	3	Short barrel	Diecast aluminium & galvanised steel (locking)	-60 (-76) - 400 (752)
VNA102I-50	4	Short barrel	Diecast aluminium & galvanised steel (locking)	-60 (-76) - 400 (752)
VNA50I-100	2	Long barrel	Diecast aluminium & galvanised steel (locking)	-60 (-76) - 400 (752)
VNA62I-100	2.5	Long barrel	Diecast aluminium & galvanised steel (locking)	-60 (-76) - 400 (752)
VNA76I-100	3	Long barrel	Diecast aluminium & galvanised steel (locking)	-60 (-76) - 400 (752)
VNA102I-100	4	Long barrel	Diecast aluminium & galvanised steel (locking)	-60 (-76) - 400 (752)

Note that assemblies include nozzle, pipe adaptor, nozzle insert and lockring. Nozzle inserts must be drilled to required orifice size. Nozzle sizes can be optimised using Goyen's GOCO software. Contact your local Goyen representative