



**EMP7**  
**Particulate Emission Monitor**  
**Installation & Operation Manual**

© Copyright by Tyco International Ltd. 2010

This manual is provided as an aid to owners of a Tyco Environmental Systems instrument and contains information proprietary to Tyco Environmental Systems.

This manual may not, in whole or part, be copied, or reproduced without the express written consent of Tyco Environmental Systems.

Goyen Controls Co Pty Ltd reserve the right to change product designs and specifications without notice.

*Rev1 – Aug 10*

# EMP7 Installation and Operation Manual

## Contents

<b>Health and Safety Information</b>	<b>iii</b>
<b>Design and Manufacturing Standards</b>	<b>iv</b>
<b>Introduction</b>	<b>1</b>
<b>Installation</b>	<b>2</b>
<b>Active Head Installation</b>	<b>4</b>
<b>Specifications</b>	<b>7</b>
<b>Maintenance</b>	<b>8</b>
<b>Purging</b>	<b>10</b>
<b>Options</b>	<b>11</b>
<b>Reference</b>	<b>12</b>
<b>Troubleshooting</b>	<b>16</b>

## Tyco Environmental Systems contact details

### Australia

#### Head Office

Goyen Controls Co Pty Ltd  
268 Milperra Road  
Milperra, NSW 2214

Telephone: 1800 805 372  
Facsimile: 1300 658 799

#### Queensland

Telephone: 1800 805 372  
Facsimile: 1300 658 799

#### Victoria

Telephone: 1800 805 372  
Facsimile: 1300 658 799

#### South Australia

Telephone: 1800 805 372  
Facsimile: 1300 658 799

#### Western Australia

Telephone: 1800 805 372  
Facsimile: 1300 658 799

### Asia

Goyen Controls Co Pty Ltd  
Shanghai Representative Office  
1209 Greenland Business Centre  
1258 Yu Yuan Road  
Shanghai PC200050  
CHINA

Telephone: 86 21 5239 8810  
Facsimile: 86 21 5239 8812

Goyen Controls Co Pty Ltd  
73-M Jalan Mega Mendung  
Kompleks Bandar OUG  
58200 Kuala Lumpur MALAYSIA

Telephone: 60 37 987 6839  
Facsimile: 60 37 987 7839

Office: Singapore  
Tel/Facsimile: 65 6457 4549

### USA

Goyen Valve Corporation  
1195 Airport Road  
Lakewood  
New Jersey 08701  
USA

Telephone: 1 732 364 7800  
Facsimile: 1 732 364 1356

### Europe

Goyen Controls Co UK Ltd  
Unit 3B Beechwood  
Chineham Business Park  
Basingstoke, Hampshire, RG24 8WA  
UNITED KINGDOM

Telephone: 44 1256 817 800  
Facsimile: 44 1256 843 164

Tyco Umwelttechnik GmbH  
Im Petersfeld 6  
D-65624 Altendiez  
GERMANY

Telephone: 49 6432 1001/1002  
Facsimile: 49 6432 63810

Mecair S.r.l.  
Via per Cinisello 97  
20054 Nova Milanese  
Milano,  
ITALY

Telephone: 39 362 375 118  
Facsimile: 39 362 375 124

[www.cleanairsystems.com](http://www.cleanairsystems.com)

## Warning

Use of controls or adjustments or procedures other than those specified in this manual may result in product failure, or poor product performance. You are cautioned that any changes or modifications to the product not expressly approved in this manual could void your product warranty.

## Important Note

The EMP7 and all associated products and this manual are subject to continuous development. Contact Tyco Environmental Systems for the latest technical information.

## Health and Safety Information

Read this before Operating or Installing the Equipment

### Equipment Operation

Use of this instrument in a manner not specified by Goyen may be hazardous.

### Electrical Power Supply

Before working on the electrical connections all of the electrical power lines to the equipment must be isolated. All the electrical cables and signal cables must be connected exactly as indicated in these operating instructions. If in doubt contact Tyco Environmental Systems.

### Face and Eye Protection

Suitable face and eye protection must be worn when working on hot vessels and ducts!

Special safety measures must be taken when working on a high-pressure duct.

### Protective Clothing

Protective clothing must always be worn when working in the vicinity of hot vessels or ducts.

### Signs and Symbols Used on Equipment and Documentation



Caution, risk of electric shock.



Caution, attention to possibility of risk of damage to the product, process or surroundings. Refer to instruction manual.

### Storage

The instrument should be stored in its packaging, in a dry sheltered area.

### Unpacking

Check all packages for external signs of damage. Check the contents against the packing note.

### Return of Damaged Goods

#### IMPORTANT

If any item has been damaged in transit, this should be reported to the carrier and to the supplier immediately. Damage caused in transit is the responsibility of the carrier not the supplier.

**DO NOT RETURN** a damaged instrument to the sender as the carrier will not then consider a claim. Save the packing with the damaged article for inspection by the carrier.

## Return of Goods for Repair

If you need to return goods for repair please contact our Customer Service Department. They will be able to advise you on the correct returns procedure.

Any item returned to Tyco Environmental Systems should be adequately packaged to prevent damage during transit.

You must include a written report of the problem together with your own name and contact information, address, telephone number, email address etc.

## Lifting Instructions

Where items are too heavy to be lifted manually, use suitably rated lifting equipment.

Refer to the Technical Specification for weights. All lifting should be done as stated in local regulations.

## Design and Manufacturing Standards

### Certifications



If applied, these symbols indicate compliance with the EMC directive and the Low Voltage directive (LVD), and with Australian/ New Zealand C-tick standards for EMC emissions and safety, including EN55011:1992, EN5082-2:1995, IEC801-4, IEC1000-4-3, IEC1000-4-2, IEC100-4-4.

### Dimensions

All measurements are given in millimetres and inches, unless otherwise stated.

## Introduction

This manual contains information relevant to the installation, commissioning and operation of the EMP7 Emission Monitors. EMP7 and all associated products and this manual are subject to continuous development, and it is acknowledged that the manual may contain errors and/or omissions. For the most up-to-date information, including applications information, the user should always refer to Tyco Environmental Systems.

### General Description

All suspended dust particles in motion accumulate an electric charge by virtue of the triboelectric effect. The EMP7 is designed to detect the motion of such charges, and therefore to detect, indicate and alarm the relative flow rate of dust in the duct, in the very low concentrations now demanded by newer legislation.

By performing a calibration process, the output signal may be adjusted so that it indicates in any required units, eg mg/s or mg/m<sup>3</sup>.

EMP7 is a single unit with wide range logarithmic 4-20mA output only.

The EMP7 head is typically mounted through the wall of a duct carrying the moving particles so that the probe is exposed to the particles. The gas stream often exhausts to atmosphere (such as in a stack), but these emission monitors are equally suited to detecting particles in motion in a gas stream under other conditions, for example pneumatically-conveyed or gravity-fed particles.

## Installation

### Planning your Installation

#### Temperature Considerations



#### Caution

If the insertion temperature is over 200°C (390°F), check with Tyco Environmental Systems to ensure that the equipment, accessories and mounting arrangements are suitable.

Although the probe model is available rated for insertion temperature 200°C (390°F) max, the ambient temperature rating in all cases is 60°C (140°F) max.

When a monitor is mounted in a duct wall, the body of the monitor will tend to rise towards the temperature of the duct wall, and may exceed the 60°C (140°F) ambient temperature rating.

If in doubt, contact Tyco Environmental Systems to ensure that your propose installation is suitable.

#### Mounting Positions

Choose a mounting position which satisfies these criteria:

In a straight section of metal duct, at least 5 diameters after or 2 diameters before any bend or screen, about 2 diameters before any isokinetic sampling point, at right angles, even further from dampers, fans, away from high vibration, ambient temperature or direct radiation, with probe axis perpendicular to the gas flow.

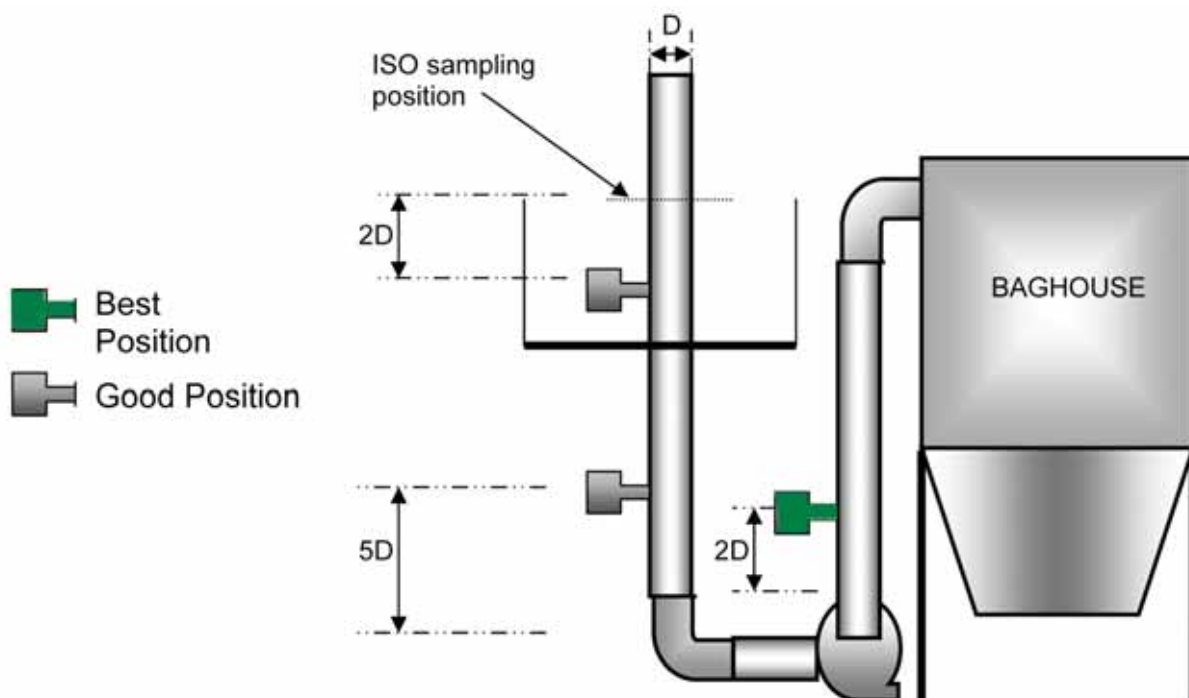

### **Grounding Of the Duct Material**

If possible, replace any insulating material (particularly plastic) which comes into contact with the gas flow, with grounded metal.

Ensure that every part of the duct and all metal exposed to the gas flow (e.g. inspection covers, fan and damper blades, isokinetic probes) are grounded.

Should there be any ungrounded metal or insulating material in contact with the gas stream, ensure that it is electrically screened from the probe (e.g., by an intermediate grounded welded mesh screen).

If in doubt, consult Tyco Environmental Systems.

### **Particle Moisture**

The Active Head should be mounted as far from the moisture source as possible, so that water droplets have evaporated, and the dust surface has dried.

If the humidity is above 80% or unstable, water droplets may appear momentarily, and be detected, increasing errors.

## Active Head Installation

### Installation Drawing

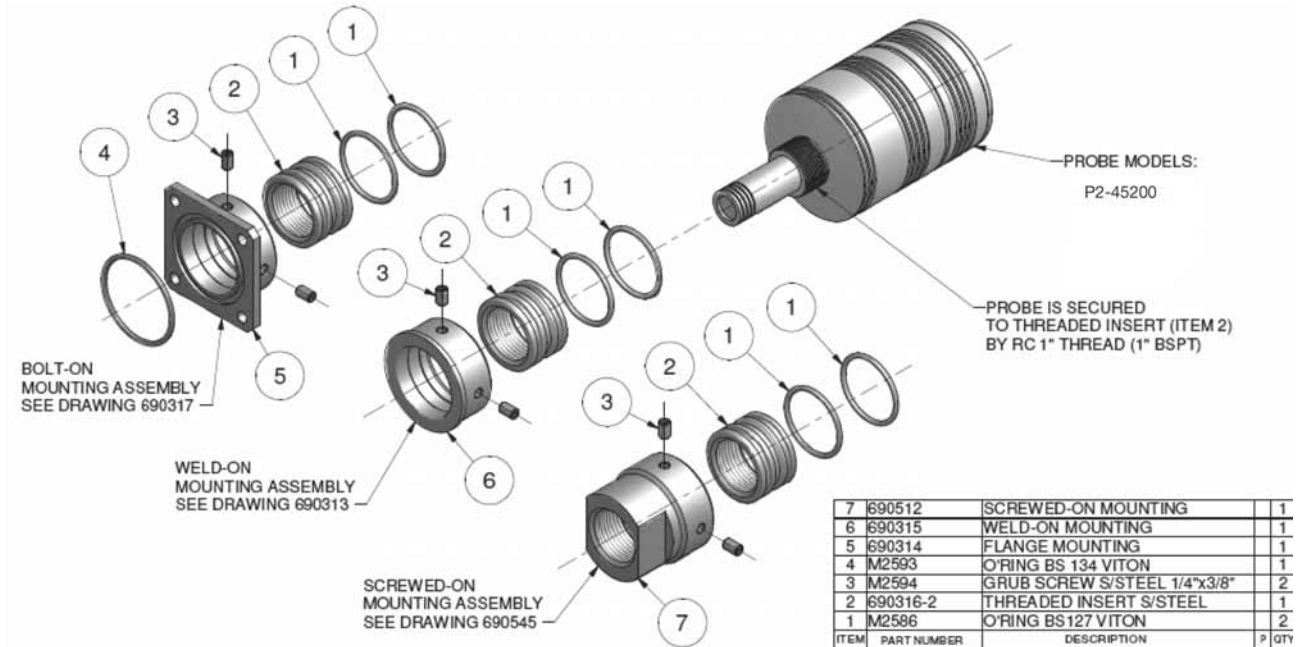

### Installation

Cut a 30mm hole in the duct, and either:

- Weld on a plain 1 inch BSPT female bush (firmly hand-tighten the monitor in the bush),
- Weld on the Weld-on Mount Kit P2-60202-SS; or
- Weld on a flange to suit Bolt-on Mount Kit P2-60203-SS.



If a mount kit is to be used it will include a metal barrel with a 1 inch BSP thread inside to suit the monitor, and two Viton O-rings outside to seal into the adapter. Screw the monitor firmly into the barrel with the chamfer outwards (see above).

Either bolt the bolt-on adapter P2-60203-SS to the duct (using the supplied Viton O-ring to seal), or weld the weld-on adapter P2-60202-SS to the duct. Then press the Monitor/barrel assembly into the adapter, apply thread sealant to the grub screws and tighten them.

*Note: Refer to the Reference section for detailed drawings.*

## Wiring

EMP7 is a 2 wire 4-20mA transmitter with internal isolation, and may be wired to an analogue input of virtually any process monitor, DCS, PLC, DAQ, SCADA, display or alarm system.

Connect the EMP7 as a 2-wire 4-20mA transmitter according to the documentation for the input system - normally like this:

### EMP7 Connection Core to

- + (positive terminal) Red +24V (analogue input system)
- (negative terminal) Black 4-20mA Analogue Input (analogue input system)

(Internal earth/drain terminal) n/a do not connect (special applications only)

Internal Lid Earth Stud Screen/drain wire Earth terminal (analogue input system)

External Lid Earth Stud Separate wire Earthed Metalwork (Duct)

Individual screened twisted-pair cable is recommended, but even non-twisted multi-core screened data cable carrying a multitude of unrelated 4-20mA signals has been found to be quite satisfactory. With a 24VDC supply and any of these types of cable, the voltage drop in cable runs up to 6000m will be acceptable.



### Caution

All electronic devices may be damaged by the application of excessive voltage. Emission monitors include protection against damage by electrostatic discharge (ESD) however in certain situations the over-voltage energy can exceed the capacity of the protective devices, so precautions are recommended:

The incorrect application of any AC or DC power source to an instrument's terminals, however briefly, will often lead to destruction of the instrument. Only make connections when it is certain they are correct.

In some industrial plants where the earthing is poor or large electrical currents or large magnetic fields are present, or near arc welding, different earth locations may exhibit different potentials, causing instrumentation cabling to carry large currents, burn out and cause a fire.

In addition, non-isolated instrumentation can suffer internal damage from earth potential differences greater than 3.5VRMS or 5V peak. Avoid any possibility of these circumstances, and ensure that arc welding is performed ONLY where the instrument is NOT connected to the work piece.

When a cable is not connected to anything, it can carry high induced voltages which, while not necessarily dangerous to humans, are nonetheless dangerous to electronic devices. When such a cable is plugged or wired into the first device, the accumulated energy is discharged into the device. To avoid damage, it is good practice to momentarily discharge any accumulated charge on the cable screen to ground, eg by shorting the two with a multimeter lead.

The human body can accumulate high electrostatic charge while walking or standing next to high voltage electrical equipment. Therefore avoid any electrical contact with the pins on the network header either directly or indirectly via a screwdriver blade. If there is a possibility that electrostatic discharge might occur to the terminals, all care should be taken to ensure no discharge occurs.

## Set-up

The 4-20mA output signal is proportional to the logarithm of the emission level.

For applications that only require simple alarm or indicator applications like plant condition monitor, broken bag detector, no special processing is needed.

Where the system is required for applications where calibration is required, while connected to a plant (eg a third-party PLC or SCADA system), a log-to-linear conversion must be performed.

Use the formula

$LIN = B \times 10^{(LOG/L)}$ , where

LIN = desired linear emission signal,

B = base value (eg 0.01mg/m<sup>3</sup>, adjust to calibrate unit to plant),

LOG = Logarithmic input signal from EMP7, as read by ADC.

L = Log Law (= 0.13 of the maximum possible value of LOG (eg if the max value of LOG is 4095, then  $L = 0.13 \times 4095 = 532$ ; adjust to trim linearity if needed).

## Specifications

### Standard Conditions

Ambient Temperature:	-20°C to 60°C (-4°F to 140°F [for electronics])
Vibration:	1G (10m/s <sup>2</sup> ) RMS max continuous, any direction or frequency (with short or separately supported wire rope probe)
Environment:	IP66/NEMA4, ATEX II 3D&G non-corrosive (Aluminium alloy body, stainless steel inserted parts).
Duct Gas Pressure:	100kPa (15 PSI) gauge max
Duct Gas Temperature:	-20°C to 200°C max (-4°F to 390°F) standard models, higher temp to order
Purge Air Pressure:	400kPa (60 PSI) max
Duct Gas Velocity:	5m/s to 30m/s (16 ft/s to 98 ft/s [virtually unlimited with appropriate probe installation])
Particle Size:	0.1µm to 1000µm (wider with some changed characteristics)
Duct Size:	50mm to 10m diameter (2in to 33ft [using the appropriate probe options])
Humidity:	0 to 80% non-condensing
Magnetic Field:	60A/m max at 50Hz (= 50Ampere-Turns in a 1m X 1m square coil)

### Mechanical

Purge Air:	RC 1/8 inch or NPT 1/8 purge air connection point is provided. Periodically pulsed purge air may reduce particulate build-up
Probe:	Removable, M8 thread fitting. 300 x 12mm stainless steel rod is standard. Probe length and type in accordance with installation requirements
Probe Options:	Solid rod, tubular, extendable, PTFE coated, tubular ceramic, wear resistant alloys, multiple supports, any length
Dimensions:	88 dia x 125 long (+18 cable gland, +70 probe mount nose)
Mounting:	1 inch male BSPT requires 1 inch female pipe fitting on duct (optional quick disconnect)

### Electrical

Power supply:	4-20mA 2-wire 10-32VDC +/-15% after cable and load voltage drops.
---------------	---

### Emission Signal

Processing Method:	Impulse Signature Extraction (ISE)
Output Signal Type:	4-20mA Logarithmic.
Resolution Typically:	0.1% of output range (2% of emission level).
Noise Immunity:	All 50Hz or 60Hz and harmonics are effectively removed from the signal before detection. However proper grounding and shielding techniques must be used to avoid mains frequency interference overloading the first amplifier.
Accuracy:	(per year and over specified Temperature range) 4-20mA Output Signal (electronics): Zero 0.6% max. Range 0.6% max. Linearity 0.6% max. After conversion to linear (electronics): Zero not applicable Range 10% max. Linearity (over 10:1 range) 10% max. Overall (typical, including plant): Zero not applicable. Range 20% Linearity over 10:1 signal range 20% untrimmed, 5% trimmed.

*All components are high stability, rated for -20°C to +60°C industrial temperature range (no trim pots).*

## Maintenance

It is desirable to periodically remove, inspect and clean the inserted parts of the Active Head. Maintenance frequency should be determined based on the material characteristics.

After initial installation the Active Head should be removed and inspected weekly then monthly to gain a working knowledge of the interval that would be required for maintenance,

Your local Tyco Environmental Systems office can aid in this process.

### Internal Self Check

Built-in self check circuitry is enabled every time the unit is powered up, ensuring the units integrity.

It is recommended that this is done at least once a month for installations that only require plant condition monitoring, systems that are calibrated should conduct this at an interval not exceeding once a week.

The procedure for this test is to remove the sensing head from the stack, disconnect the probe shaft, power down for a period of 30sec to enable the built in self check,. While the device is conducting the internal self check the mA output will be at 5mA, this will last about 30sec.

If the result of the internal self check fails then the instrument will fail to 3.8mA and hold this value until rectified (please see fault-finding for possible remedies).

### Inspection

This is a visual inspection to ensure that the system is good working order.

As these devices are typically mounted outdoors inspection of cabling, moisture ingress and general condition of the monitor is vital.

Things to look for are:

- Moisture ingress into the body of the monitor.
- Warn of frayed cabling.
- Any burn marks on termination.
- Tightening of all screws (terminals, lid, probe shaft etc.)
- Particulate build-up on the sensor front end and probe shaft.

## Cleaning

Cleaning of the probe is a vital part of the maintenance process to ensure that no bridging occurs between the probe shaft and any grounded material.

Particles can build-up across the probe shaft to the “coat shield” and even to the duct wall, resulting in a LOW reading from the monitor.

To clean the monitor it needs to be removed from the stack and all inserted parts cleaned with compressed air. See image below for components to be cleaned.

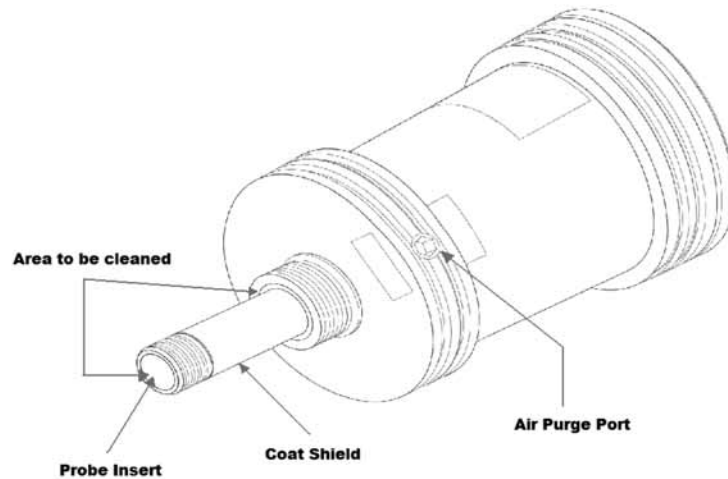

Air purging can help to minimise the frequency of cleaning.

## Purging

### Particulate Build-up

Particulate build-up on the probe itself can be minimised by the use of PTFE coated probes (consult Tyco Environmental Systems), however build-up on the probe will not cause errors in any case. Build-up across the insulation barrier from the probe to the earthed metalware will, however, progressively attenuate the emission signal, so it should be avoided where possible. A low level alarm can be configured to detect this condition.

### Connecting the Purge Air

If build-up across the insulators is considered to be a potential problem, then the purge port must be connected to a source of periodically pulsed clean dry instrument air to dislodge recently deposited particles. The pulsed air will flow as indicated below. NEVER exceed the rated pressure of the purge port (400kPa/60 PSI), or over tighten the air fitting. If the purge facility is not used, the original sealing plug and O-ring must be fitted at all times.

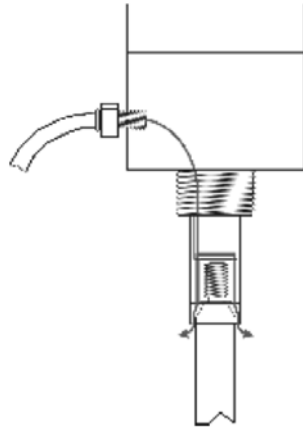

### Corrosive Gases

If the gas is corrosive, it should not be allowed to enter the body of the Monitor; in these circumstances the purge air path can be sealed off completely by a plug inserted before the probe is screwed in (please see the supplier).

## Options

### Probe Options

The Emission Monitor Active Head is widely adjustable; however probe length also has a significant effect on sensitivity, so choose the probe length according to these recommendations:

- Below 1mg/m<sup>3</sup>: 0.8 duct diameters
- Above 100mg/m<sup>3</sup>: 0.1 duct diameters
- Otherwise: 0.5 duct diameters

Probes are traditionally formed from solid stainless steel rod. However stainless steel wire rope is also available for new models, and is available on request for all other models. Wire rope has a number of advantages over solid rod:

- The surface texture and small diameter minimise downstream gas flow disturbances to flow transmitters, isokinetic sampling probes, etc
- The high internal damping eliminates resonance effects which can damage probes and Emission Monitors
- The inherent sagging minimises the probability of a probe unscrewing itself in operation
- The wire strands slide slightly against each other with normal movement of the probe in the gas stream, which tends to dislodge accumulated matter.

Wire rope probes are commonly fitted in one of these forms:

- Cantilevered probe 0-800mm: use a simple wire rope probe alone.
- Probe 800-2000mm total: supported on opposite side by P2-60230 support head.
- Probe above 2000: string the probe across the duct with egg insulators in line at both ends, and strong supports. Add another short section of stainless steel wire to connect the Emission Monitor to the probe.

Alternatively, consult Tyco Environmental Systems to discuss other probe options including: rigid rod, PTFE coated rod, rod or rope in wear-resistant material.

### Temperature Options

The monitor may be mounted via an extension tube such as the high temp kits P2-60205 (300mm) or P2-60210 (450mm). A reflective metal heat shield (eg 400mm dia ss) may be clamped along the extension tube using two nuts on the threaded exterior of the tube.

Provided the gas path is at negative pressure and non-toxic (the usual case for a stack) and the emission monitor body is protected from rain or other contaminants, the monitor may be cooled by drilling several holes around the outermost end of the extension tube, thus allowing ambient air to coat the emission monitor's nose and part of the probe. By these means it is possible to use monitors rated for 200°C (390°F) max insertion temperature at gas temperatures of up to 500°C (P2-60205) or 600°C (P2-60210).

### Hazardous Area Options

Please contact you local Tyco Environmental Systems office for information.

### Mounting Options

If a quick-release tapping point is required, the Bolt-on Mount Kit P2-60203-SS or the Weld-on

## Reference

### Mounting Assembly Drawings

<b>No</b> 691138	<b>SHEET</b> 1
------------------	----------------

**BOLT-ON MOUNTING ASSEMBLY**  
SEE DRAWING 690317

**WELD-ON MOUNTING ASSEMBLY**  
SEE DRAWING 690313

**SCREWED-ON MOUNTING ASSEMBLY**  
SEE DRAWING 690545

PROBE MODELS:  
P2-45200

PROBE IS SECURED TO THREADED INSERT (ITEM 2) BY RC 1" THREAD (1" BSPT)

ITEM	PART NUMBER	DESCRIPTION	QTY
1	M2586	ORING BS127 VITON	2
2	690316-2	THREADED INSERT S/STEEL	1
3	M2594	GHUB SCREW S/STEEL 1/4"x3/8"	2
4	M2593	ORING BS 134 VITON	1
5	690314	FLANGE MOUNTING	1
6	690315	WELD-ON MOUNTING	1
7	690512	SCREWED-ON MOUNTING	1

  

1	RELEASE	ECRO 8256	DATE	30.1.08
MATERIAL SPEC.		AUTHORISED		
TEST SPEC.		TOLERANCE		
PROCESS SPEC.		UNLESS OTHERWISE STATED		
NOTE: COPYRIGHT IN THIS DRAWING RESTS IN GOYEN CONTROLS CO. PTY. LTD. 888-282 MILPERRA RD. MILPERRA N.S.W. 2114 AUSTRALIA		DO CHECK		
		DATE 30/01/2008		
		DRAWN Kdunn		

<p><b>GOYEN</b> is the first choice for Control Technology Solutions that enhance the reliability, quality &amp; productivity of our Customers' Control Systems.</p>	<p><b>2ND ANGLE PROJECTION</b></p> <p>SCALE NTS</p> <p>TITLE <b>GENERAL ARRANGEMENT PROBE MOUNTING OPTIONS</b></p> <p>FIRST USED ON</p> <p>NO <b>691138</b></p>
--	---

No 690317 SHEET 1

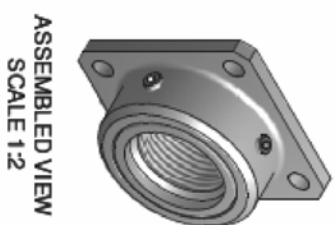
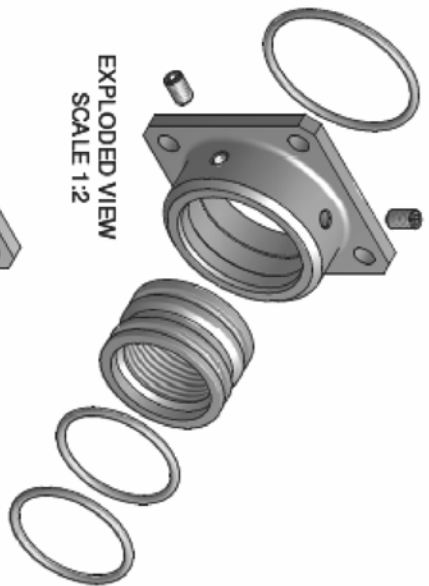
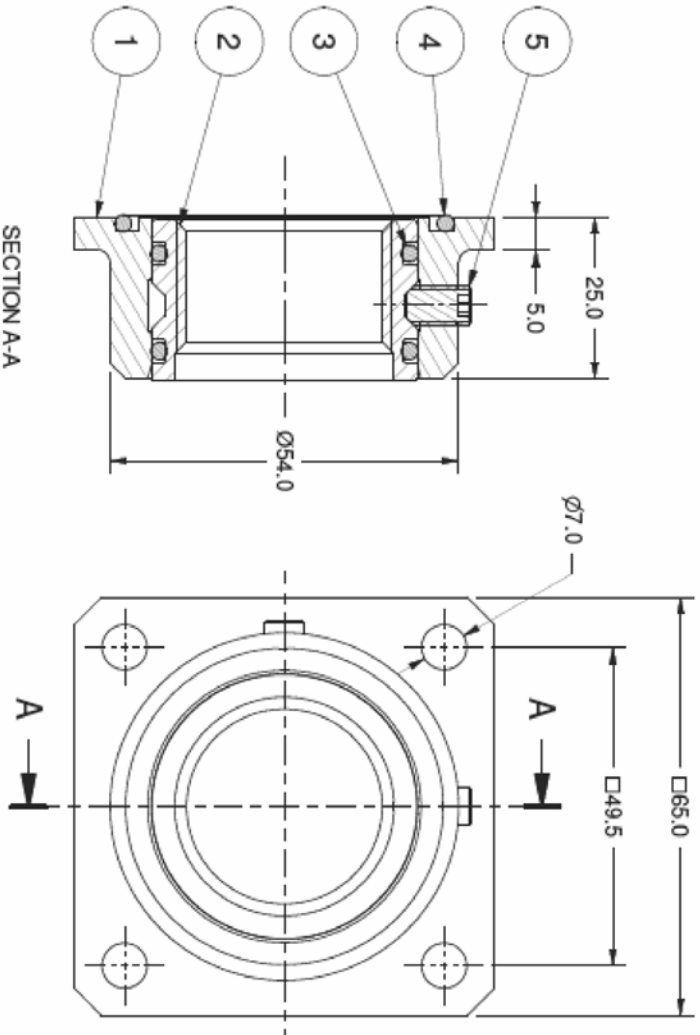

MODEL: P2-60203-SS

2	REDRAWN IN INVENTOR	EGRO 8256	D.O.CHECK	
1	PRODUCTION RELEASE	16.1.08	DATE	16/01/2008
1	ISS	EGRO 4289	DRAWN	Kolumi
	DETAILS OF CHANGE	15.6.94	AUTHORISED	
MATERIAL SPEC.			TOLERANCE UNLESS OTHERWISE STATED LINEAR ±0.2 ANGULAR ±0.5	
TEST SPEC.			REMOVE ALL BURRS, FLASH & SHARP EDGES: MAX. 0.2x45° or 0.2 RAD.	
PROCESS SPEC.			DIMENSIONS IN MILLIMETERS UNLESS OTHERWISE SPECIFIED DO NOT SCALE DRAWING	
NOTE: COPYRIGHT IN THIS DRAWING VESTS IN GOYEN CONTROLS CO. PTY. LTD. 288-292 MILPERRA RD. MILPERRA N.S.W. 2214 AUSTRALIA				

  

ITEM	PART NUMBER	DESCRIPTION	QTY
5	M2504	1/4"x3/8" GRUB SCREW S/STEEL	2
4	M2593	O/RING BS134 VITON	1
3	M2586	O/RING BS127 VITON	2
2	690316-2	THREADED INSERT	1
1	690314	FLANGE MOUNTING	1

SCALE 1:1		TITLE <b>BOLT-ON PROBE MOUNTING ASSEMBLY</b>
SHEET 1	OF 1	
FIRST USED ON		NO 690317

No 690313 SHEET 1

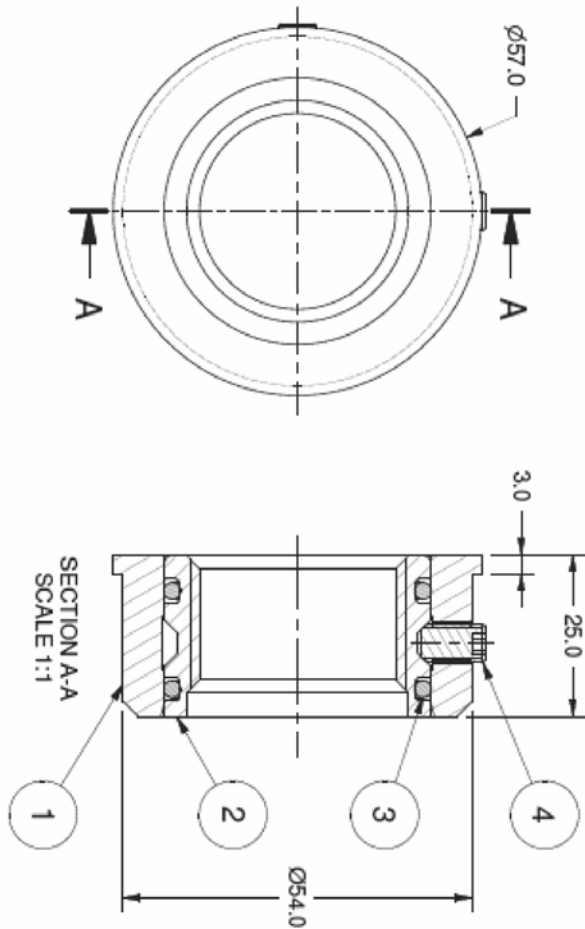

MODEL: P2-60202-SS

ITEM	PART NUMBER	DESCRIPTION	P	QTY
4	M2594	1/4"X3/8" GRUB SCREW S/STEEL		2
3	M2586	O-RING BS127 VITON		2
2	690316-2	THREADED INSERT		1
1	690315	WELD-ON PROBE MOUNTING		1

2	REDRAWN IN INVENTOR	ECRO 8256	
	690316-2 WAS 690316	16.1.08	
1	PRODUCTION RELEASE	ECRO 4289	RRB
		16.6.94	
ISS	DETAILS OF CHANGE	ECRO DATE	AUTHORISED

D.O.CHECK	
DATE	17/01/2008
DRAWN	Kdunn

MATERIAL SPEC.		TOLERANCE	UNLESS OTHERWISE STATED
TEST SPEC.			LINEAR ±0.2 ANGULAR ±0.5°
PROCESS SPEC.			REMOVE ALL BURRS, FLASH & SHARP EDGES: MAX. 0.2x45° or 0.2 RAD.
			DIMENSIONS IN MILLIMETERS UNLESS OTHERWISE SHOWN DO NOT SCALE DRAWING
SCALE	1:1	TITLE	WELD-ON PROBE MOUNTING ASSEMBLY
SHEET	OF		
FIRST USED ON	1	NO	690313

**GOYEN** is the first choice for Control Technology Solutions that enhance the reliability, quality & productivity of our Customers' Control Systems.

NOTE: COPYRIGHT IN THIS DRAWING VESTS IN GOYEN CONTROLS CO. PTY. LTD. 288-292 MILPERISA RD. MILPERISA N.S.W. 2114 AUSTRALIA

A4

No 690545 SHEET 1

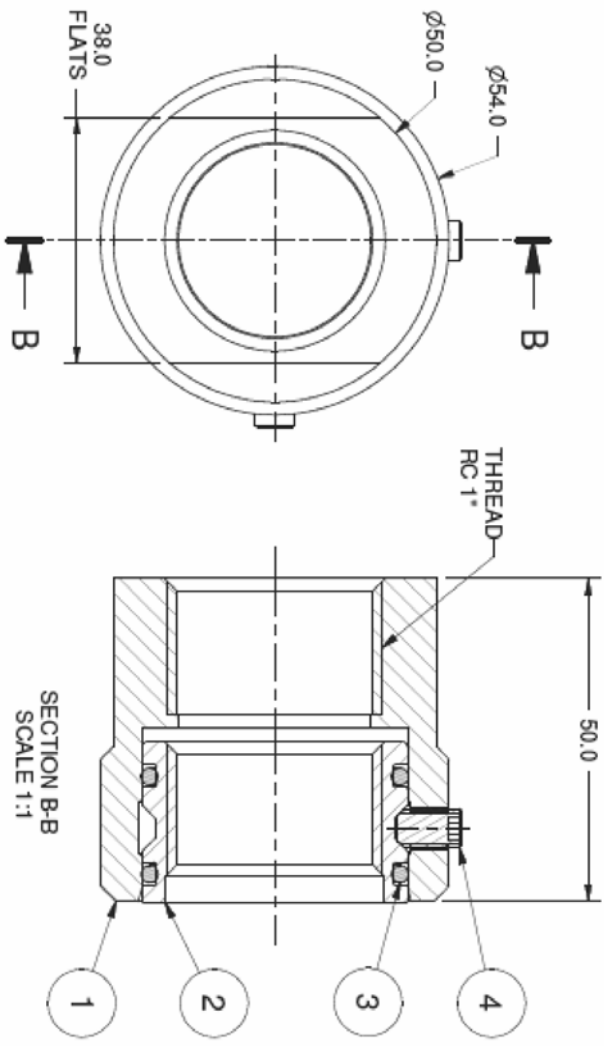

MODEL: P2-60204-SS

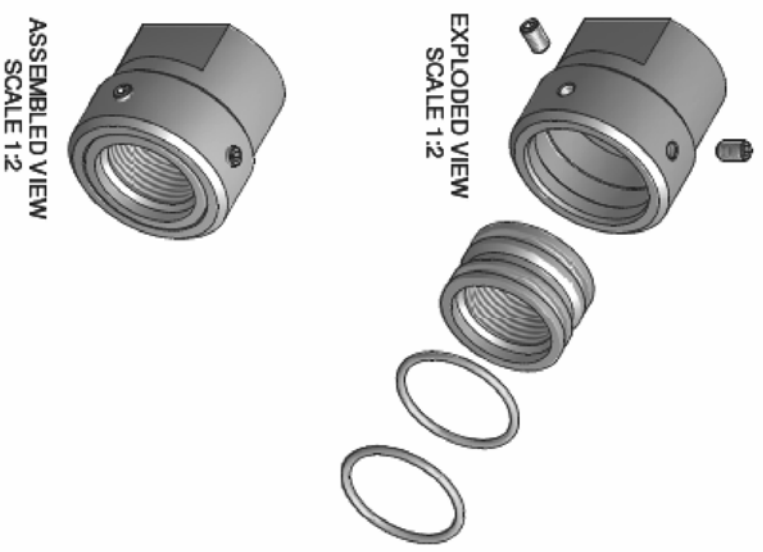

2	REDRAWN IN INVENTOR	ECRO 8256	D.O.CHECK	4	M2594	1/4"x3/8" GRUB SCREW STEEL	2
1	PRODUCTION RELEASE	ECRO 3259	DATE 14/12/2007	3	M2586	O-RING BS127 VITON	2
		18.10.98	DRAWN kduinn	2	690316-2	THREADED INSERT	1
				1	690512	SCREWED-ON COUPLING	1

ISS	DETAILS OF CHANGE	ECRO DATE	AUTHORISED
MATERIAL SPEC.			
TEST SPEC.			
PROCESS SPEC.			

TOLERANCE UNLESS OTHERWISE STATED		TITLE	
LINEAR ±0.2 ANGULAR ±0.5		SCREWED-ON PROBE MOUNTING ASSEMBLY	
REMOVE ALL BURRS, FLASH & SHARP EDGES: MAX. 0.2x45° or 0.2 RAD.		NO	
DIMENSIONS IN MILLIMETERS UNLESS OTHERWISE SHOWN DO NOT SCALE DRAWING		690545	

NOTE: COPYRIGHT IN THIS DRAWING VESTS IN GOYEN CONTROLS CO. PTY. LTD. 288-292 MILPERRA RD. MILPERRA N.S.W. 2214 AUSTRALIA

## Troubleshooting

Problem	Possible Cause/s	Remedy
No Signal	No power to the device Incorrect input being read in data input device Probe shaft not connected Bridging of the probe shaft to ground	Apply power Ensure that input connections have been made to the correct location Connect probe shaft. Probe needs to be cleaned (see maintenance).
Erratic Signal	No earth wire connected  Earth potential is above recommendation  Loose connection to probe shaft Ambient temperature has exceeded the rating for the monitor/control unit (60°C, 140°F)	Connect external earthing lug to ground Earthing point needs to be improved to eliminate high potential Ensure that the probe shaft is tight Steps need to be taken to ensure the temperature does not exceed the rating, contact Tyco Environmental Systems for further assistance
Device is outputting 3.8mA	Device failed during internal self-check  Device has failed due to other reason	Remove the probe shaft from the instrument and conduct test again  Probe needs to be cleaned (see maintenance) and conduct test again  If the above fails to rectify the problem contact Tyco Environmental Systems.
Device showing lower than usual signal	Emissions from the stack have decreased  Bridging of the probe shaft to ground  No probe shaft connected	Actual emissions have decreased no action needs to be taken Probe need to be cleaned (see maintenance) Ensure probe shaft is connected and tight

If the problem cannot be rectified by following these steps, contact Tyco Environmental Systems.

## Notes

 **GOYEN**

**tyco** | *Flow Control* | **Environmental Systems**