



## *Analysers*



## Description

Greenspan Analysers are the answer to your automatic analysis requirements. Designed and manufactured in Australia, in conjunction with development by CSIRO and other Australian research organisations, Greenspan Analysers can provide a complete solution for automatic water analysis of chemical and physical parameters. When combined with external monitoring equipment, Greenspan Analysers can provide you with a comprehensive environmental monitoring system.

Greenspan Analysers can perform chemical and physical analyses automatically, that are comparable to laboratory style analysis. The analysers are housed in IP54 lockable cabinets that can be temperature controlled allowing them to be used in even the harshest of environments.

## User Defined Settings

You can define which tests within the analyser are performed by setting up to 25 different schedules. These schedules can be run periodically, on a selected timetable, or initiated by an event such as a parameter exceeding user-defined levels. External triggers, such as a depth sensor, can also be used to initiate a schedule.

The flexibility of these analysers allows you to configure a system that will perform your required analyses in a timely fashion, capturing critical events that would possibly be missed under a grab sample regime. This ability to discretely select the tests and dictate the frequency of analyses required, provides you with a cost-effective monitoring solution.

## Configured to your Requirements

Each analyser houses a chemistry module designed specifically to suit your requirements. Whether for an environmental study or for use in a wastewater application, they can be configured with the required methodologies to suit your monitoring needs.

## External Inputs and Triggers

All analysers come ready to collect data from eight external inputs such as flow, rainfall or depth sensors, creating a complete automatic environmental data collection system.

External samplers can be triggered during critical events to capture samples for further laboratory investigation.

## Data Storage and Software

On-board data storage preserves all logged values, pending transmission, wherever the data is required. Data can be easily uploaded from the analyser at any time. Greenspan Analysers come complete with, easy to use, Windows based software.

The software can be used for simple maintenance tasks or to provide you with a complete package of data that can be presented in either tabular or graphical formats.

Data can be exported in many common formats for further analysis and integration into other software packages. The software allows you to define preset sampling intervals, setup alarm functions and event based triggering routines.

## Representative Block Diagram

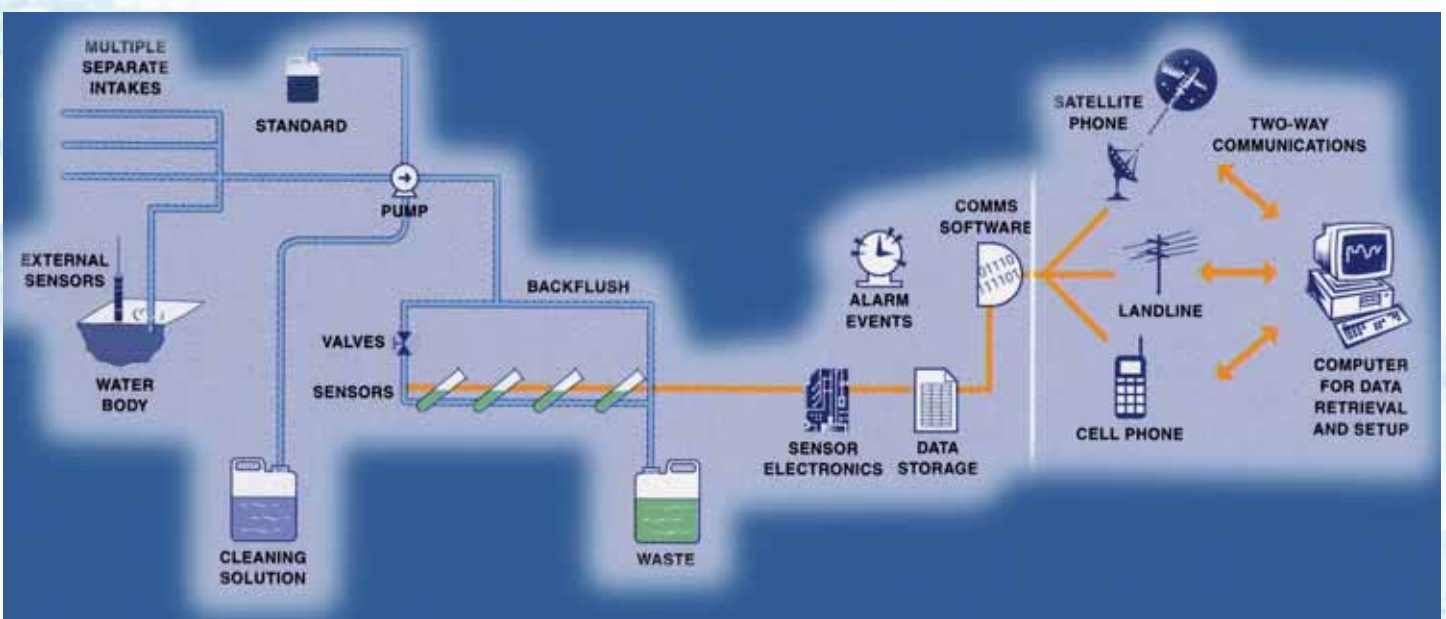

## Guaranteed Representation Sample

Greenspan's unique sample delivery system, with back-flushing of all sample and inlet lines, guarantees the elimination of sample carry-over and contamination, ensuring optimum analytical performance for every measurement. Multiple intake lines via optional manifold can be connected allowing for multi-point sample analysis.

## Power Supply

A 12VDC lead acid battery can power the electronics module of the analysers. This can be used as a backup to keep the analyser operational for several days without mains power. In extremely remote locations the battery power source can be configured to run from a solar-powered regulated supply.

## Communication Options

Data collected by these analysers can be transmitted directly to your desktop computer using a variety of telemetry options. Choose from mobile phone, landline, radio or satellite communications. Greenspan turnkey telemetry systems include all housings, antennae and accessories to get your data to where you need it most. Local communication options include direct connect via an RS232 comms port.

Alternatively, the analysers can provide a 4-20mA output direct to your existing control system.

## Dynamic Calibration

Each analyser utilises on-board reagents and standards equivalent to those used in laboratory methods. All reagent and standard bottles are colour coded to match intake lines in the analyser. This makes the task of changing over chemicals a simple and quick exercise.

Varied bottle sizes can be selected to ensure that the maximum unattended operation time is achieved. Reagent and standard volumes are delivered with precision to the chemistry module by a unique pumping and valve system. User-defined intervals of automatic calibration ensure accurate and reliable data 24 hours a day.

## Remote Diagnosis

Remote diagnostic and interrogation capabilities via a terminal emulator such as HyperTerminal allow Greenspan service staff to diagnose potential problems and assist on-site staff anywhere in the world.

The major benefit for our customers is that service staff can identify and rectify any problem that the operator may have without having to visit the remote site. The cost saving that this can achieve is self-evident.

Ion Selective Electrodes (ISE) are used for direct measurement of Ammonia/ Ammonium and nitrate. pH determination is performed by a flat-faced glass electrode that does not impede sample flow thereby avoiding possible blockage. The sensors are mounted on an acrylic block that allows for easy maintenance.

## Parameter Methodology

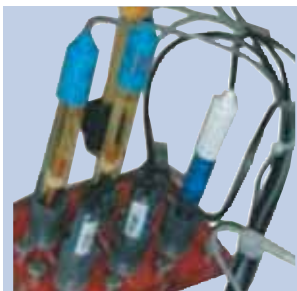

Ion Selective Electrodes (ISE) are used for direct measurement of Ammonia/ Ammonium and nitrate. pH determination is performed by a flat-faced glass electrode that does not impede sample flow thereby avoiding possible blockage. The sensors are mounted on an acrylic block that allows for easy maintenance.



A flow cell measures Electrical Conductivity with two electrodes using alternating current to avoid electrode polarisation.



A galvanic cell oxygen electrode determines Dissolved Oxygen. A semi-permeable membrane allows oxygen molecules to pass into the internal electrolyte; reduction at the gold cathode produces a voltage output that is temperature compensated and proportional to oxygen concentration.



An ammonia gas electrode is modulated in a special flow cell. This flow cell incorporates a stirrer for more rapid determination of ammonia.



A nephelometer is used to determine Turbidity. Light is passed through a cell containing sample and the scattered light is measured by a detector orientated 90° to the light path.

## Aqualab

'Aqualab' is the flagship of the Greenspan Analyser range. Configurable parameter analysis and telemetry options provide Aqualab with the ability to solve various monitoring questions. This analyser offers a single system capable of providing data for a wide range of monitoring needs. It is a configurable analyser allowing you to select the appropriate chemistry package for your application from wastewater to environmental monitoring.

Aqualab can be configured to perform any selection of physical parameters (pH, electrical conductivity, dissolved oxygen, turbidity, temperature and oxidation reduction potential -ORP) and nutrient parameters (total reactive phosphorus, nitrate, ammonia and ammonium)

The Aqualab analytical system is housed in a weatherproof IP54 cabinet. The cabinet also houses the communication and control electronics along with reagent and standard solution storage bottles.



## Parameters and Specifications

Parameter	Method	Range	Overall Accuracy
pH	Glass electrode Std Method 4500-H B	2-12	+/- 0.4 pH
EC	Conductivity cell Std. Method 2520-B	0-2,000µS/cm	+/- 2% FS
DO	Galvanic cell Std. Method 4500-O G	0-20 mg/l	+/- 0.2 mg/l
ORP	Platinum electrode Std. Method 2580-B	+/-1000mV	+/- 5% FS
Turbidity	Nephelometer Std. Method 2130-B	0 - 2,000 NTU	+/- 2.5% FS
Nitrate	ISE Std. Method 4500-N03 D	0.1-14mg/l	+/- 5%
Phosphate (TRP)	Colorimetric Std. Method 4500-P E	0.1-3ppm	+/- 2%
Ammonia	Gas Electrode STD. Method 4500-NH3 D	0-14 mg/l	+/- 5%
Ammonium	ISE	0.3-14 mg/l	+/- 5%
Total Phosphorus	Colorimetric Std. Method 4500-B	3-360 ppb or 0.1-3 ppm	+/- 2%
Parameter	Analysis Frequency		
Physical Parameters	10 to 30 minutes (dependent on set-up)		
Nutrient parameters	50 minutes		
Nitrate	15 minutes		
Phosphate (TRP)	12 minutes		
Ammonia	20 minutes		
Ammonium	15 minutes		
Total Phosphorus	30 minutes		
Specifications			
Enclosure	IP 54	Power Average	15.6VA
Dimensions	365x400x430 (WxHxD)	Voltage	85-264 VAC
Cabinet Weight	75kgs	Alarms	System and Sample
Processor	80C188	Sampler Output	Optional
Data Storage	1Mb Total 491K for Data Storage	Output	4-20 mA or SDI-12 optional
Display	Optional back lit LCD	External Inputs	Up to 8 x 4 - 20 mA
Calibration	User Definable	Scheduling	25 User Defined Schedules
Sample Flow Rate	20-60L/min	Communications	Landline, GSM or Satellite
Ambient Conditions	5-50°C	Interrogation	RS232
		Software	Analyser 32/Aquagraph

Other ranges and parameters available on request

## Mini-Analyser

The Mini-Analyser, Greenspan's newest and smallest analyser can provide a tailored solution to your specific monitoring needs. Designed specifically to suit certain monitoring situations such as environmental monitoring, industrial discharge or single point of source monitoring, you're sure to find a configuration of the Mini-Analyser that is ready to take on your specific monitoring task.

Designed to be either wall, trailer or bench-top mounted, this compact analyser is the solution for continuous unattended analysis and is packed with additional features.

## Mini Analyser Configurations

The Mini-Analyser can be configured one of three ways:

**Physicals:** Configured to perform pH, electrical conductivity, dissolved oxygen, turbidity, temperature and oxidation reduction potential - ORP analysis.

**Nutrients:** Configured to perform total reactive phosphorus, nitrate, ammonia or ammonium.

**Single Channel:** Can be configured to perform single analysis of any one of the following: total reactive phosphorus, nitrate, ammonia or ammonium.



## Parameters and Specifications

Parameter	Method	Range	Overall Accuracy
<b>Physicals</b>			
pH	Glass electrode Std Method 4500-H B	2-12	+/- 0.4 pH
EC	Conductivity cell Std. Method 2520-B	0-2,000µS/cm	+/- 2% FS
DO	Galvanic cell Std. Method 4500-O G	0-20 mg/l	+/- 0.2 mg/l
ORP	Platinum electrode Std. Method 2580-B	+/-1000mV	+/- 5% FS
Turbidity	Nephelometer Std. Method 2130-B	0 - 2,000 NTU	+/- 2.5% FS
<b>Single Channel and Nutrients</b>			
Nitrate	ISE Std. Method 4500-N03 D	0.1-14mg/l	+/- 5%
Phosphate (TRP)	Colorimetric Std. Method 4500-P E	0.1-3ppm	+/- 2%
Ammonia	Gas Electrode STD. Method 4500-NH3 D	0-14 mg/l	+/- 5%
Ammonium	ISE	0.3-14 mg/l	+/- 5%
<b>Parameter</b>	<b>Analysis Frequency</b>		
<b>Physical</b>	10 to 30 minutes (dependent on set-up)		
<b>Nutrient</b>	50 minutes		
<b>Single Channel</b>			
Nitrate	15 minutes		
Phosphate (TRP)	12 minutes		
Ammonia	20 minutes		
Ammonium	15 minutes		
<b>Specifications</b>			
Enclosure	IP 54	Voltage	85-264 VAC
Dimensions	365x400x430 (WxHxD)	Alarms	System and Sample
Weight	25kgs	Sampler Output	Optional
Processor	80C188	Output	4 - 20 mA or SDI-12 optional
Data Storage	1Mb Total, 491K for Data Storage	External Inputs	Up to 8 x 4 - 20 mA
Display	Optional back lit LCD	Scheduling	25 User Defined Schedules
Calibration	User Definable	Communications	Landline, GSM or Satellite
Sample Flow Rate	20-60L/min	Interrogation	RS232
Ambient Conditions	5 - 50°C	Software	Analyser 32/Aquagraph
Power Average	15.6VA		

Other ranges and parameters available on request

## Analyser Characteristics

On board standards and dynamic calibration, in association with standard laboratory methodologies, ensures that the Aqualab and Mini-Analysers will provide accurate and laboratory comparable data.

The functionality of the Aqualab and Mini-Analyser allows for unattended operation with a minimum of field visits and the advantage that data review, system monitoring and diagnostics can all be performed via your desktop PC.

## Features

The Aqualab has

- Sample Data Variation Alarms
- System Alarms
- Remote Data Acquisition
- Remote Diagnostics
- Optional Temperature Control Unit

The Aqualab chemistry module is designed with upgrade requirements in mind.

## Aqualab Features



As new sensor technologies develop you can be assured they will be able to be easily implemented into your existing system either as a new configuration or an add-on module.

The Mini Analyser has:

- Sample Data Variation Alarms
- System Alarms
- Optional Touch Sensitive LCD
- Remote Data Acquisition
- Remote Diagnostics

## Mini-Analyser Features



## Applications

### River monitoring

Greenspan Analysers are used extensively to monitor river water quality prior to extraction for treatment and distribution by the water supply network. Continuous measurement of physical parameters such as turbidity and electrical conductivity together with ammonium monitoring provides the water supply manager the necessary information to optimise process plant efficiencies.

The effects of land use on river quality can be monitored 24 hours per day, particularly to capture critical events, which would go unnoticed with normal grab sample procedures.

### Wastewater

The on-line monitoring of nutrient levels in wastewater treatment plants affords efficient control and operation of the biological reactor tanks in achieving nutrient reduction.

The final discharge can be continually assessed to ensure that regulatory levels of nutrients in the effluent are adhered to.

### Wetlands

Operating unattended in remote areas monitoring the impact of human and agricultural nutrient levels on wetlands, Greenspan Analysers provide the necessary information to assess the effects of management on the wetlands in order to avoid eutrophication and assist in maintaining fauna and flora of the ecosystem.

### Harbour monitoring

Discharges from ships in harbours impact the quality of estuarine and coastal waters.

Greenspan Analysers are used in conjunction with external sensors linked to the system, to monitor physical and nutrient levels and alert to the possible pollution of the waters.

### Aquaculture

Small changes to water quality in aquaculture ventures can dramatically affect production yields. Greenspan analysers can assist farm operators to maintain the best possible levels of nutrients to maximize returns on their investments.

The dial-out alarm functionality of Greenspan analysers can alert farm operators to changes as they occur. Analysers can also be used to help the farms meet regulatory discharge requirements.

## Benefits of Greenspan Analysers

- Remote analysis systems requiring minimum operator intervention.
- When linked to external instrumentation, they can provide a complete environmental monitoring system.
- Provide data 24 hours per day allowing you to capture critical events.
- All the data you need goes directly to your desktop in graphical or tabular formats.
- They provide system control and data acquisition from other instruments to optimise plant control.
- They provide laboratory comparable data by using standard methods.
- Reduced costs associated with laboratory analysis.
- Remote system monitoring and diagnosis reduces field visits.
- Easy-to-use simplistic operating software.
- Proven analytical system with 70+ field installations and growing.

## Examples of Current Installations

Below is a sample of some of our current analyser sites:

- State Environmental Protection Agency - China
- Ministry of Water Resource - China
- Jiangsu Provincial EPA - China
- Selangor Water Board - Malaysia
- Brisbane Water - Australia
- Hastings Council - Australia
- Caboolture Shire Council - Australia
- Redcliffe City Council - Australia
- Texas Commission on Environmental Quality - USA
- Public Procurement Department - Korea

**Greenspan Analysers can provide you with an accurate, reliable and cost effective data collection system 24 hours a day anywhere in the World.**



#### **Australia**

Head Office  
Goyen Controls Co Pty Ltd  
268 Milperra Road  
Milperra, NSW 2214

Telephone: 1800 805 372  
Facsimile: 1300 658 799

#### **Queensland**

Telephone: 1800 805 372  
Facsimile: 1300 658 799

#### **Victoria**

Telephone: 1800 805 372  
Facsimile: 1300 658 799

#### **South Australia**

Telephone: 1800 805 372  
Facsimile: 1300 658 799

#### **Western Australia**

Telephone: 1800 805 372  
Facsimile: 1300 658 799

#### **Asia**

Goyen Controls Co Pty Ltd  
Shanghai Representative Office  
1209 Greenland Business Centre  
1258 Yu Yuan Road  
Shanghai PC200050  
CHINA

Telephone: +86 21 5239 8810  
Facsimile: +86 21 5239 8812

Goyen Controls Co Pty Ltd  
73-M Jalan Mega Mendung  
Kompleks Bandar OUG  
58200 Kuala Lumpur MALAYSIA

Telephone: +60 37 987 6839  
Facsimile: +60 37 987 7839

#### **Office: Singapore**

Tel/Facsimile: +65 6457 4549

#### **USA**

Goyen Valve Corporation  
1195 Airport Road  
Lakewood  
New Jersey 08701  
USA

Telephone: +1 732 364 7800  
Facsimile: +1 732 364 1356

#### **Europe**

Goyen Controls Co UK Ltd  
Unit 3B Beechwood  
Chineham Business Park  
Basingstoke, Hampshire, RG24 8WA  
UNITED KINGDOM

Telephone: +44 1256 817 800  
Facsimile: +44 1256 843 164

Tyco Umwelttechnik GmbH  
Im Petersfeld 6  
D-65624 Altdendiez  
GERMANY

Telephone: +49 6432 95299 0  
Facsimile: +49 6432 95299 24

Mecair S.r.l.  
Via per Cinisello 97  
20054 Nova Milanese  
Milano,  
ITALY

Telephone: +39 0362 3751  
Facsimile: +39 0362 367279